



SOUTH VILLAGE CONDOS AT LATIMER HEIGHTS





SOUTH VILLAGE CONDOS AT LATIMER HEIGHTS

SITE PLAN





SOUTH VILLAGE CONDOS

AT LATIMER HEIGHTS

LIVE IN THE HEART OF IT ALL

- Located adjacent to Latimer Heights Community Pond – enjoy the best view of the neighborhood.
- Connected to the neighborhood walking and trail network that offers dog parks, bike paths and sports fields.
- Across from the South Village Condos is Latimer Village- a walkable European style retail village boasting local shops, restaurants, cafes – linked by a park and a scenic pond with pedestrian bridge.
- Easy access to Highway 1 to Coquitlam, Burnaby and Vancouver or Abbotsford and the Fraser Valley.
- A short walk to Carvolth bus exchange, largest transit hub in Langley for a seamless bus ride to sky train station for easy commute to Vancouver Downtown.
- Conveniently located close to Langley Event Centre, Walnut Grove Community Centre, and Willoughby Town Centre.

STEP INSIDE

- Sophisticated collection of two six-storey modern buildings featuring one-two-and-three-bedroom condos with flex options.
- Smartly designed homes with open floor plans and two on trend color schemes to choose from – Storm and Sand.
- Bright living spaces with abundant natural light from expansive windows.
- Large contemporary livable spaces with 9' ceilings and spacious secondary bedrooms.
- Energy efficient and compact Air Conditioning system in the main living area.
- Durable and tasteful hardwood-style laminate flooring throughout.
- Modern, sleek, and slim quartz countertops.
- USB charging stations throughout.

KITCHENS THAT INSPIRE

- Modern recessed and under-cabinet lighting brightens and adds ambiance.
- Soft close cabinets and drawers.

- Enjoy everyday luxury of an island or peninsula with extra storage.
- Contemporary stainless steel basin kitchen sink.
- Surprisingly plentiful cabinet storage plus a bonus spacious pantry cupboard with pull out shelving (most homes).
- Complete Samsung series home appliance package:
 - Separate laundry/closet with energy efficient front-loading washer and dryer
 - Stainless steel 5-burner gas cooktop with integrated hood fan
 - Stainless steel under cabinet built-in microwave
 - Double French door fridge with convenient slide-out freezer
 - Stainless steel dishwasher with integrated functions

REJUVENATING BATHROOMS

- Luxuriate in a deep soaker tub with stylish tile surround.
- Beautifully designed soft-close oak laminate cabinetry with sophisticated hardware.
- Main bathroom features elegant accent wall with floor to ceiling tiles.
- Oversized designer selected floor tiles add to modern timeless home interiors.
- Contemporary faucets with undermount sinks and quartz countertops.
- Frameless glass showers in ensuite bathrooms.

PROUDLY BUILT BY VESTA

- Vesta built homes come with the promise of quality and exceptional workmanship.
- A designated homeowner portal for access to customer service, warranty information, home care tips, etc.
- All homes include secure underground parking, EV charging stations and storage.



SOUTH VILLAGE CONDOS AT LATIMER HEIGHTS

KEY PLAN BUILDING A

LEVEL 5

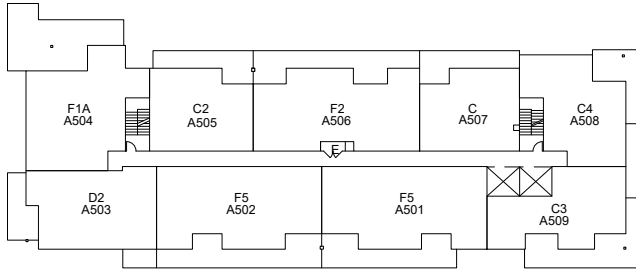

LEVEL 6

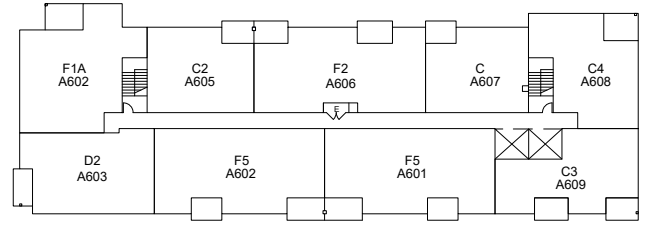

LEVEL 2

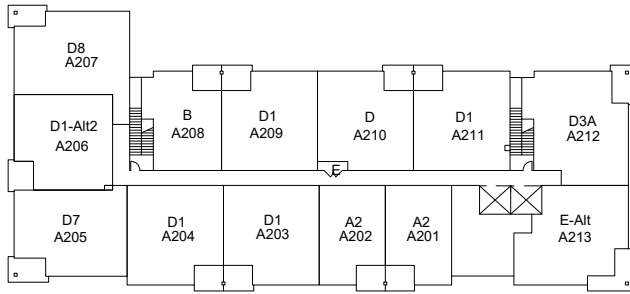

LEVEL 3-4

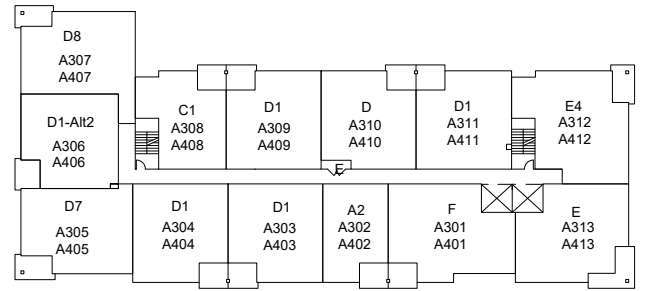

LEVEL 1

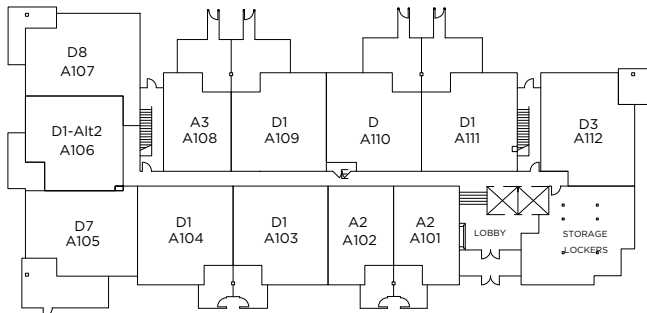



SOUTH VILLAGE CONDOS
AT LATIMER HEIGHTS

PLAN A2 adapt.

658 SQ.FT.

1 BED | 1 BATH

ONE BEDROOM

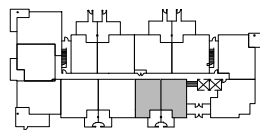
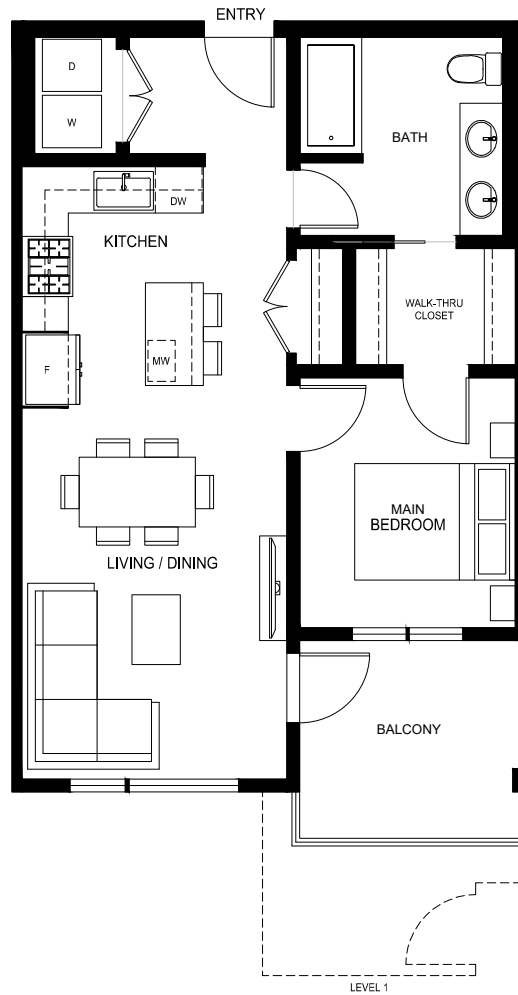

LEVEL 1

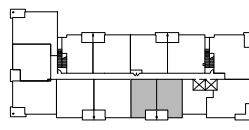

LEVEL 2

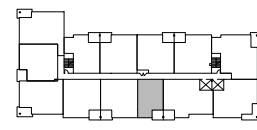

LEVEL 3-4





SOUTH VILLAGE CONDOS
AT LATIMER HEIGHTS

PLAN A3
678 SQ.FT.
1 BED | 1 BATH

ONE BEDROOM

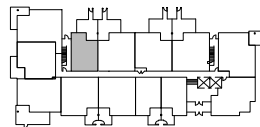
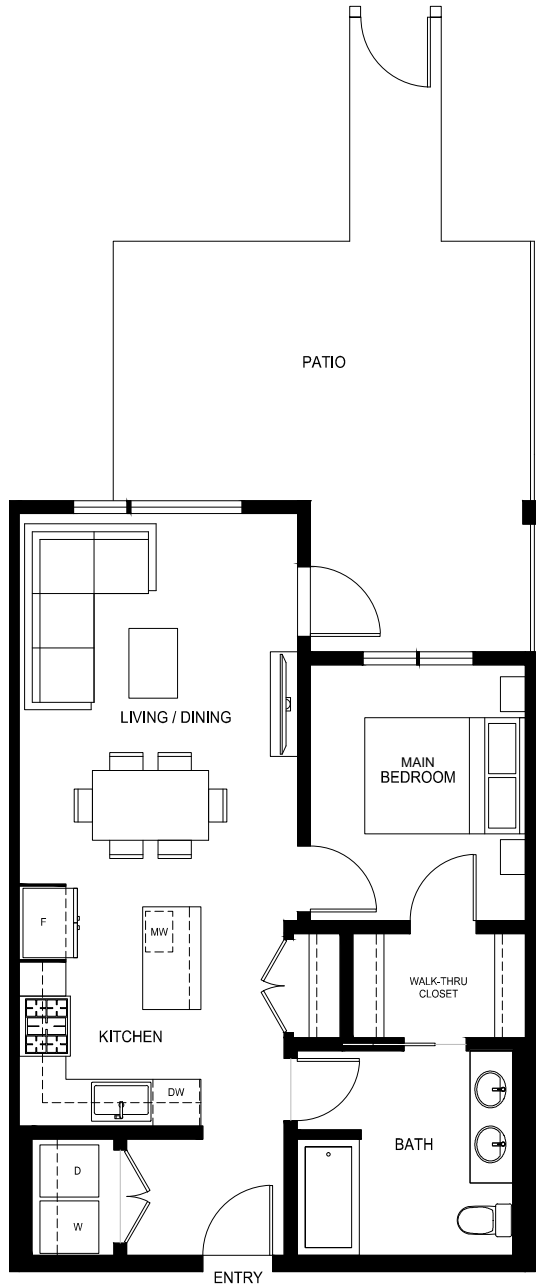

LEVEL 1





SOUTH VILLAGE CONDOS
AT LATIMER HEIGHTS

PLAN C
793 SQ.FT.
2 BED | 2 BATH

TWO BEDROOM

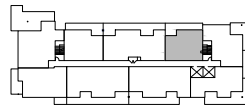
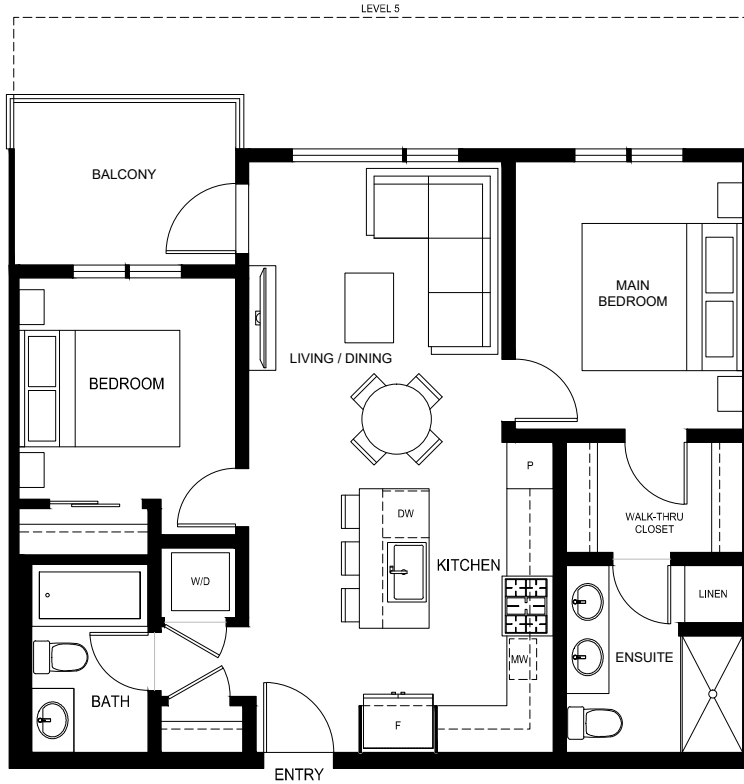

LEVEL 5

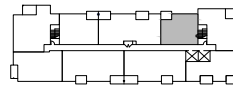

LEVEL 6





SOUTH VILLAGE CONDOS
AT LATIMER HEIGHTS

PLAN C1
789 SQ.FT.
2 BED | 1 BATH

TWO BEDROOM

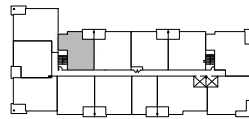
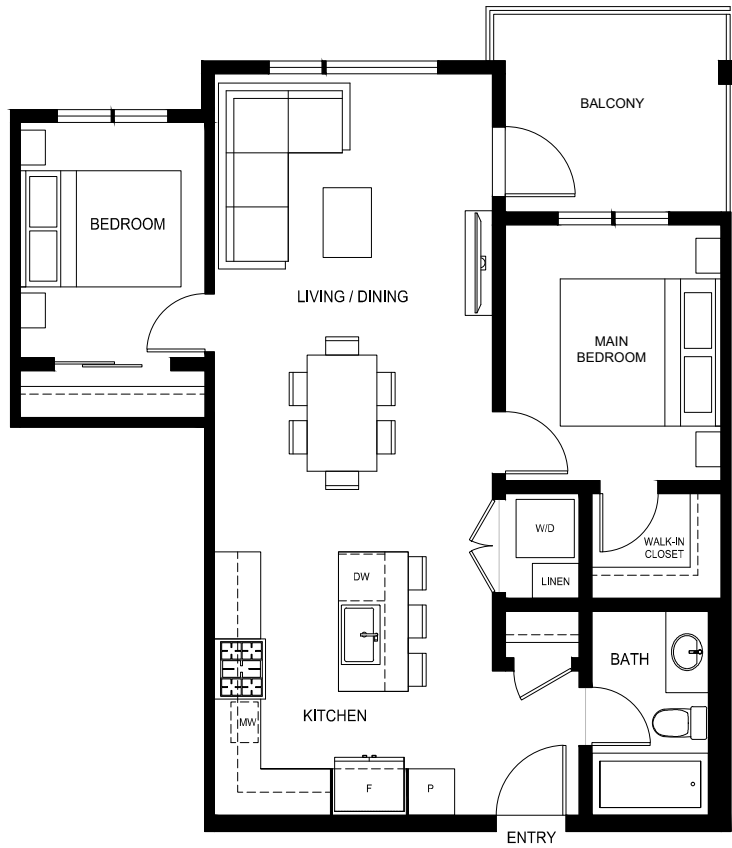

LEVEL 3-4





SOUTH VILLAGE CONDOS
AT LATIMER HEIGHTS

PLAN C2
820 SQ.FT.
2 BED | 2 BATH

TWO BEDROOM

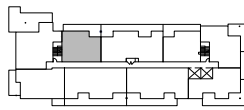
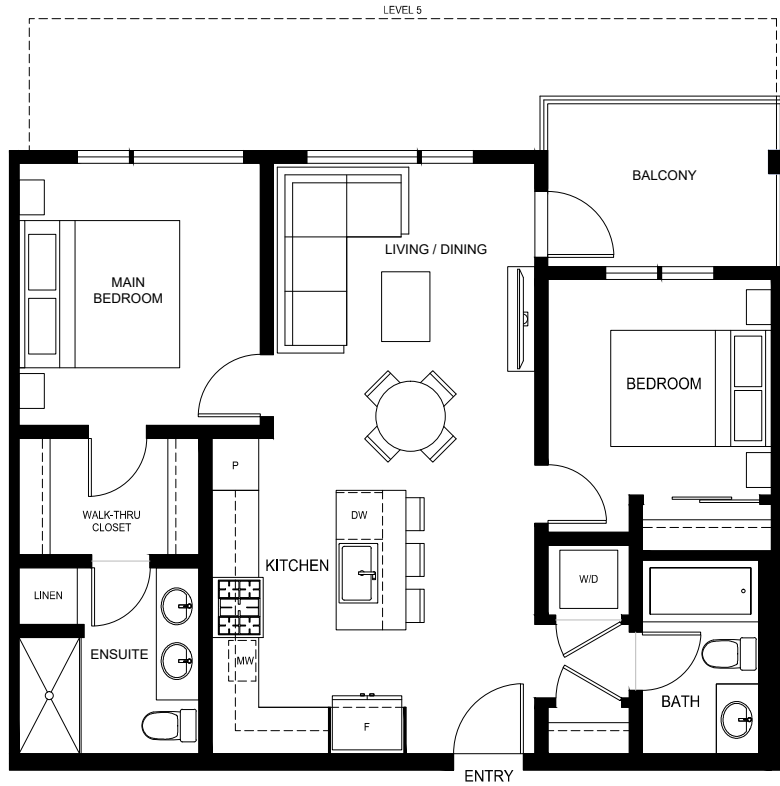

LEVEL 5

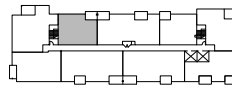

LEVEL 6





SOUTH VILLAGE CONDOS
AT LATIMER HEIGHTS

PLAN C3
880 SQ.FT.
2 BED | 2 BATH

TWO BEDROOM

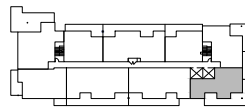
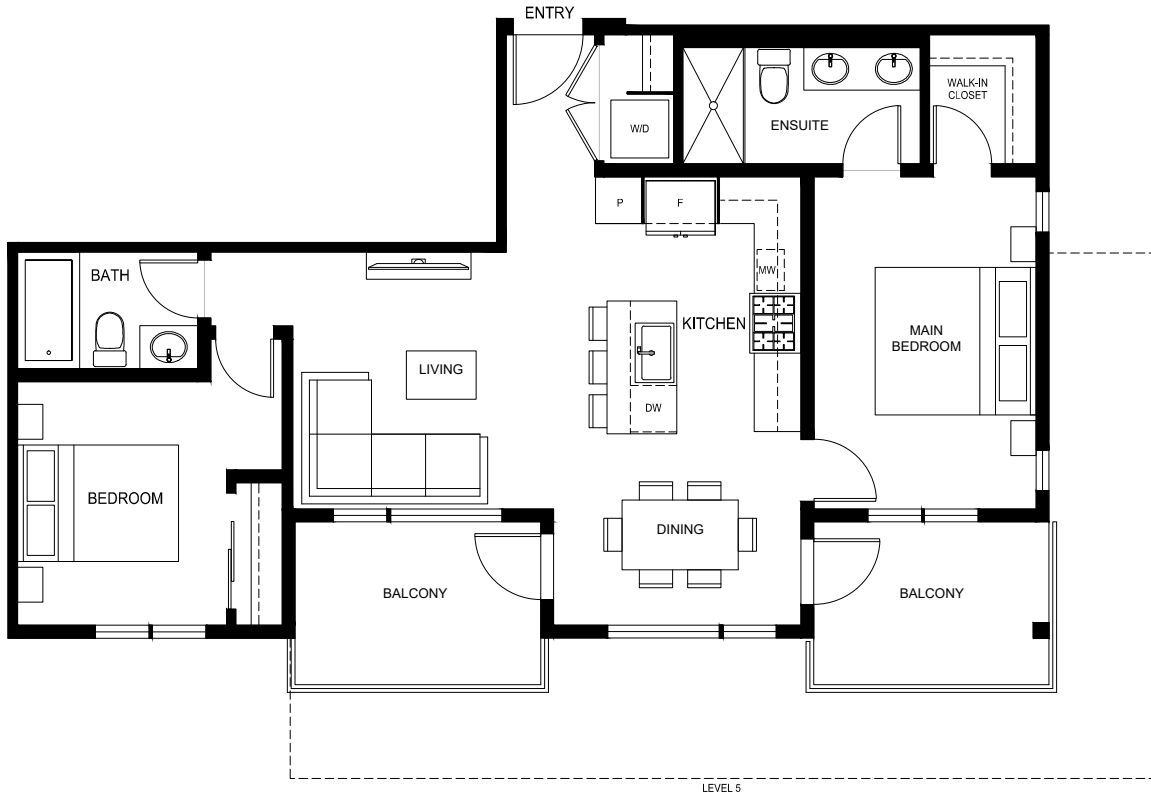

LEVEL 5

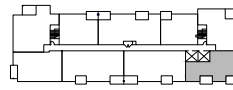

LEVEL 6





SOUTH VILLAGE CONDOS
AT LATIMER HEIGHTS

PLAN C4
934 SQ.FT.
2 BED | 2 BATH

TWO BEDROOM

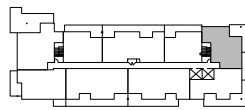

LEVEL 5

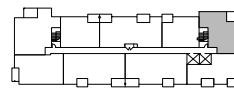

LEVEL 6





SOUTH VILLAGE CONDOS AT LATIMER HEIGHTS

PLAN D

955 SQ.FT.

2 BED + FLEX | 2 BATH

TWO BEDROOM

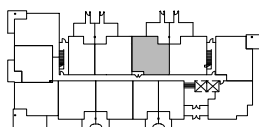
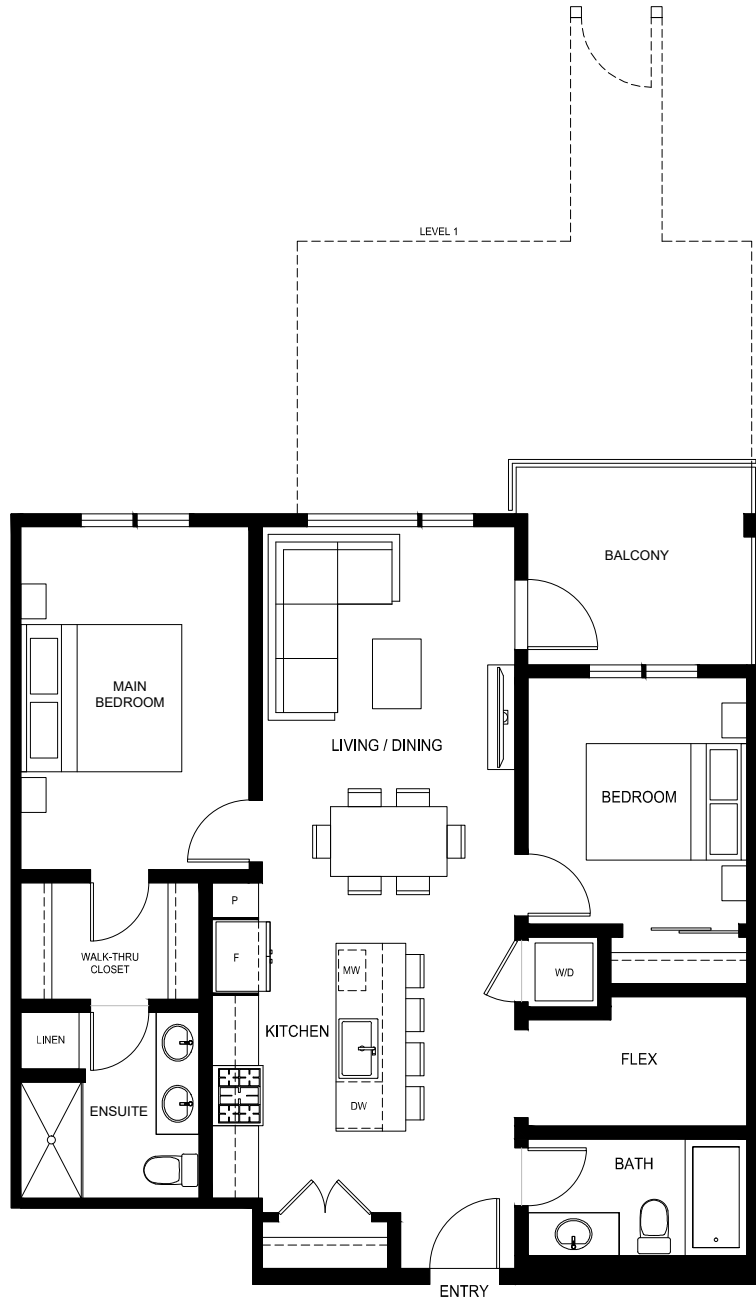

LEVEL 1

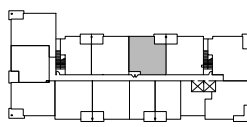

LEVEL 2

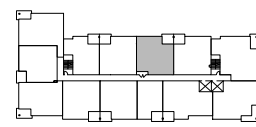

LEVEL 3-4





SOUTH VILLAGE CONDOS AT LATIMER HEIGHTS

PLAN D1

986 SQ.FT.

2 BED + FLEX | 2 BATH

TWO BEDROOM

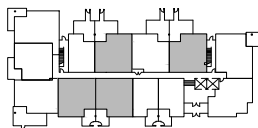
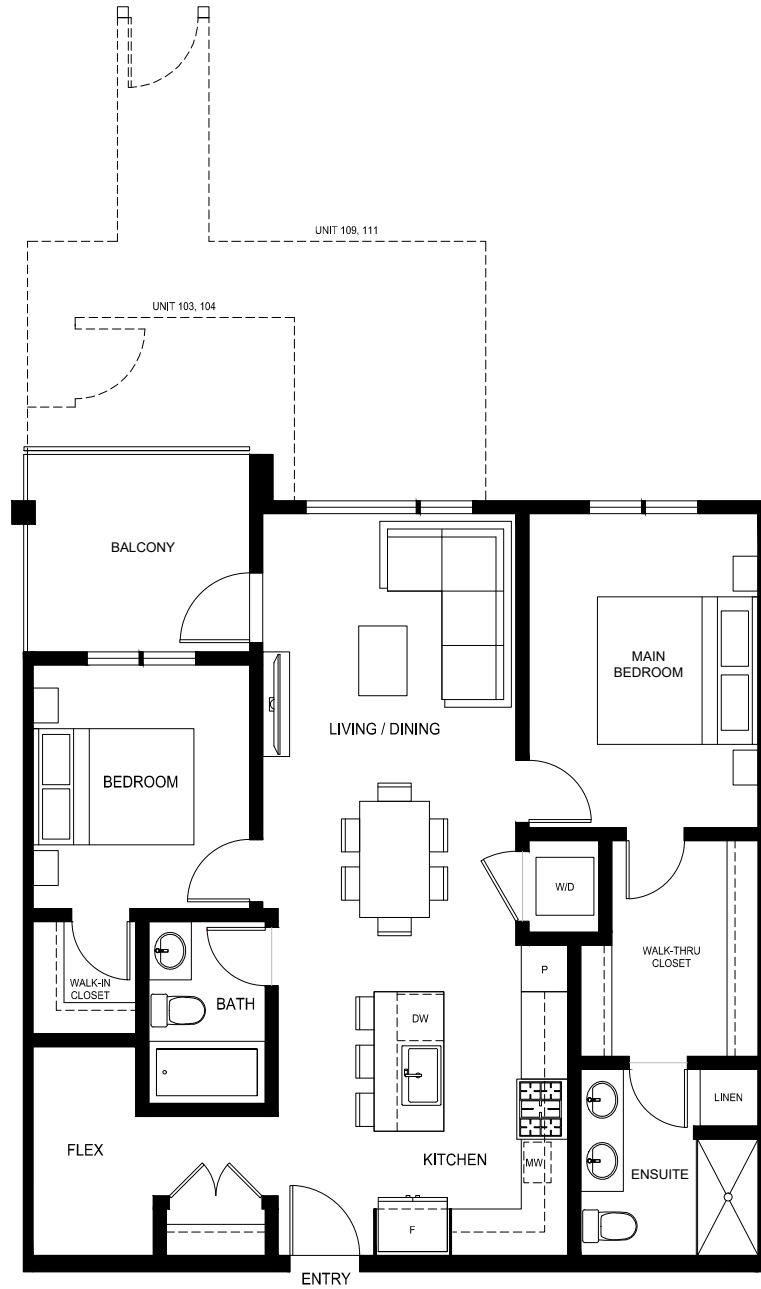

LEVEL 1

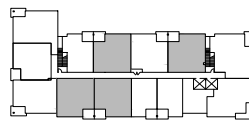

LEVEL 2

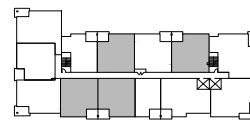

LEVEL 3-4





SOUTH VILLAGE CONDOS
AT LATIMER HEIGHTS

PLAN D1-alt2

973 SQ.FT.

2 BED + FLEX | 2 BATH

TWO BEDROOM

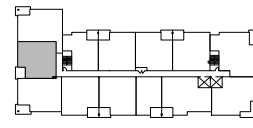
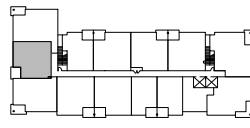
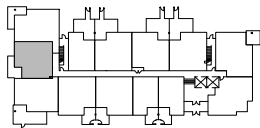
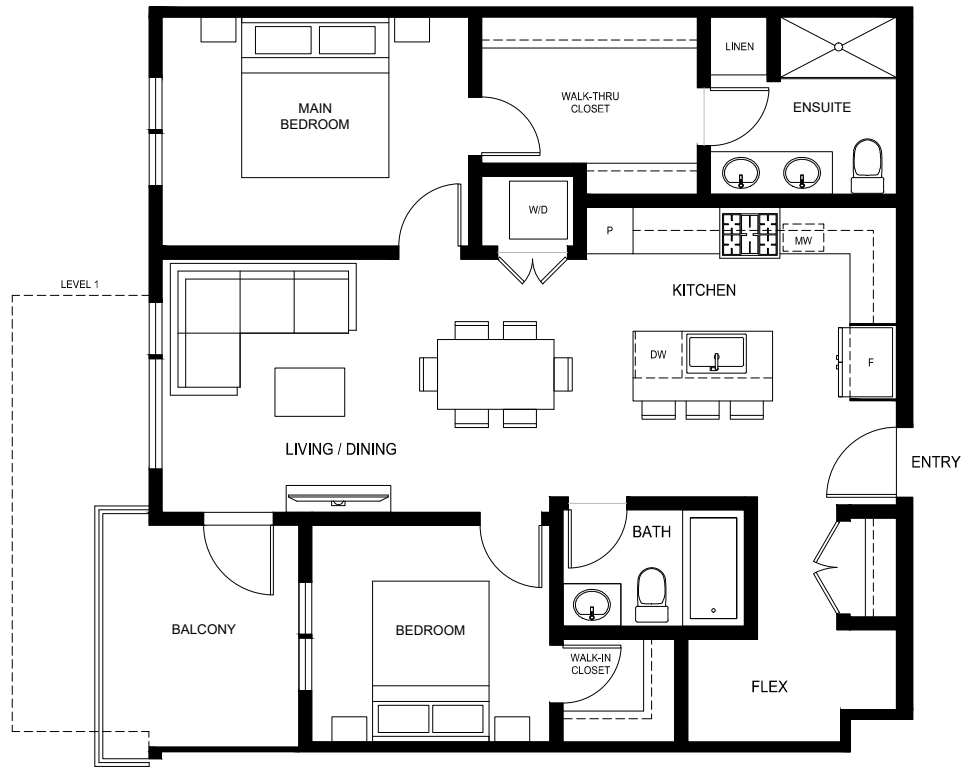



SOUTH VILLAGE CONDOS
AT LATIMER HEIGHTS

PLAN D3

1,091 SQ.FT.

2 BED + FLEX | 2 BATH

TWO BEDROOM

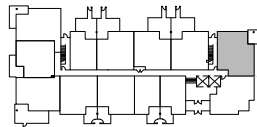
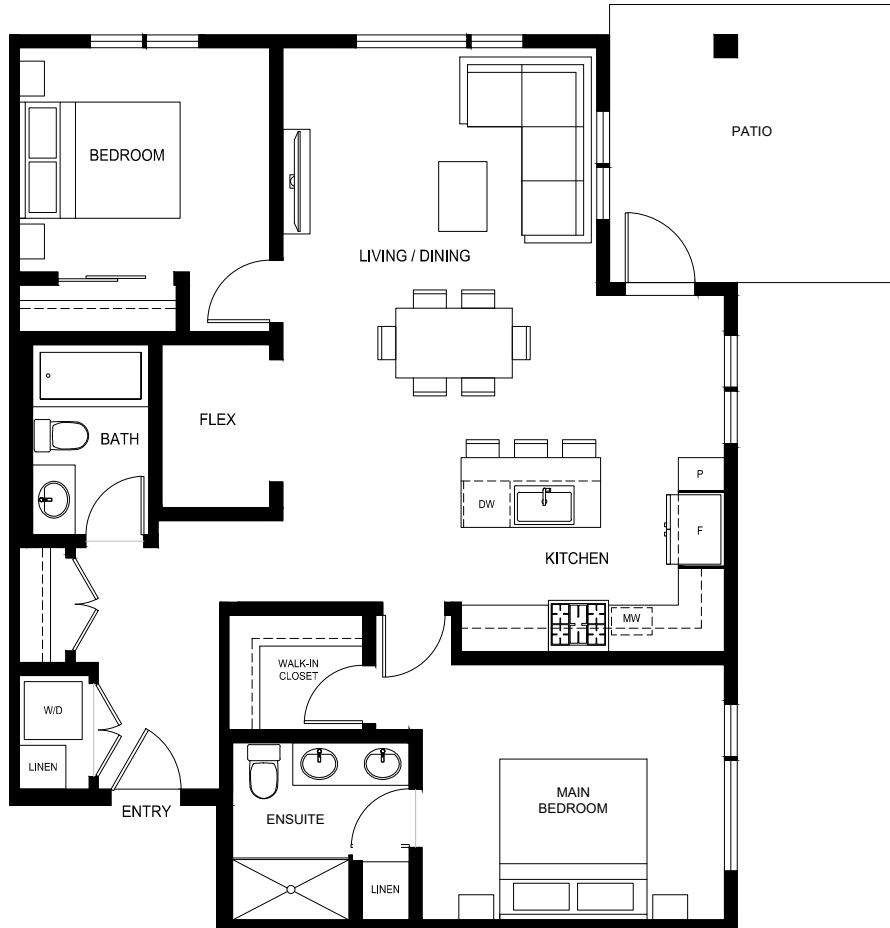

LEVEL 1





SOUTH VILLAGE CONDOS
AT LATIMER HEIGHTS

PLAN D3a

1,147 SQ.FT.

2 BED + FLEX | 2 BATH

TWO BEDROOM

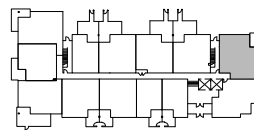
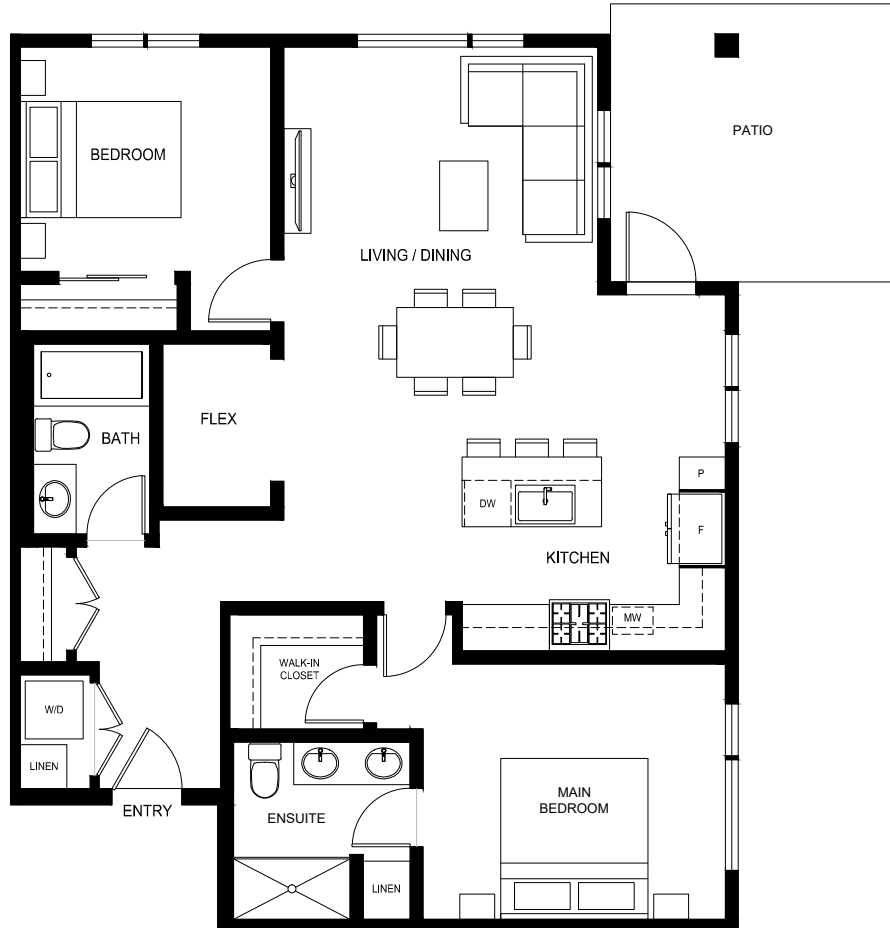

LEVEL 1





SOUTH VILLAGE CONDOS
AT LATIMER HEIGHTS

PLAN D2
1,009 SQ.FT.
2 BED | 2 BATH

TWO BEDROOM

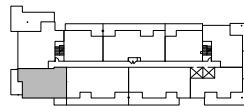
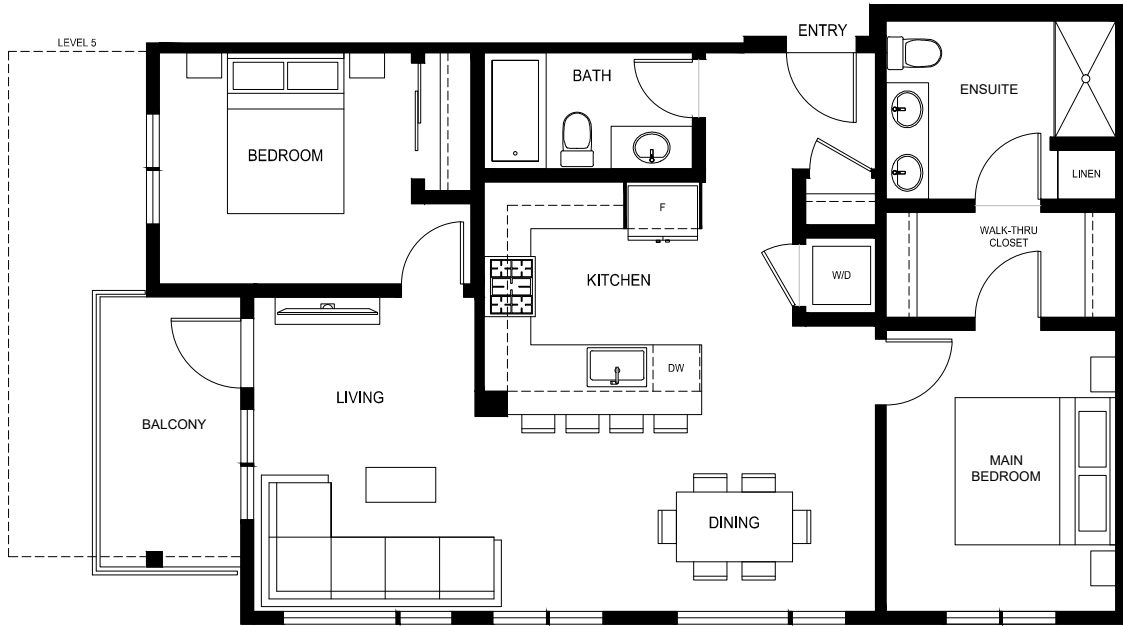

LEVEL 5

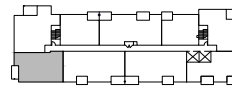

LEVEL 6





SOUTH VILLAGE CONDOS AT LATIMER HEIGHTS

PLAN D7 1,020 SQ.FT. 2 BED | 2 BATH

TWO BEDROOM

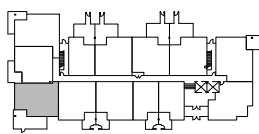
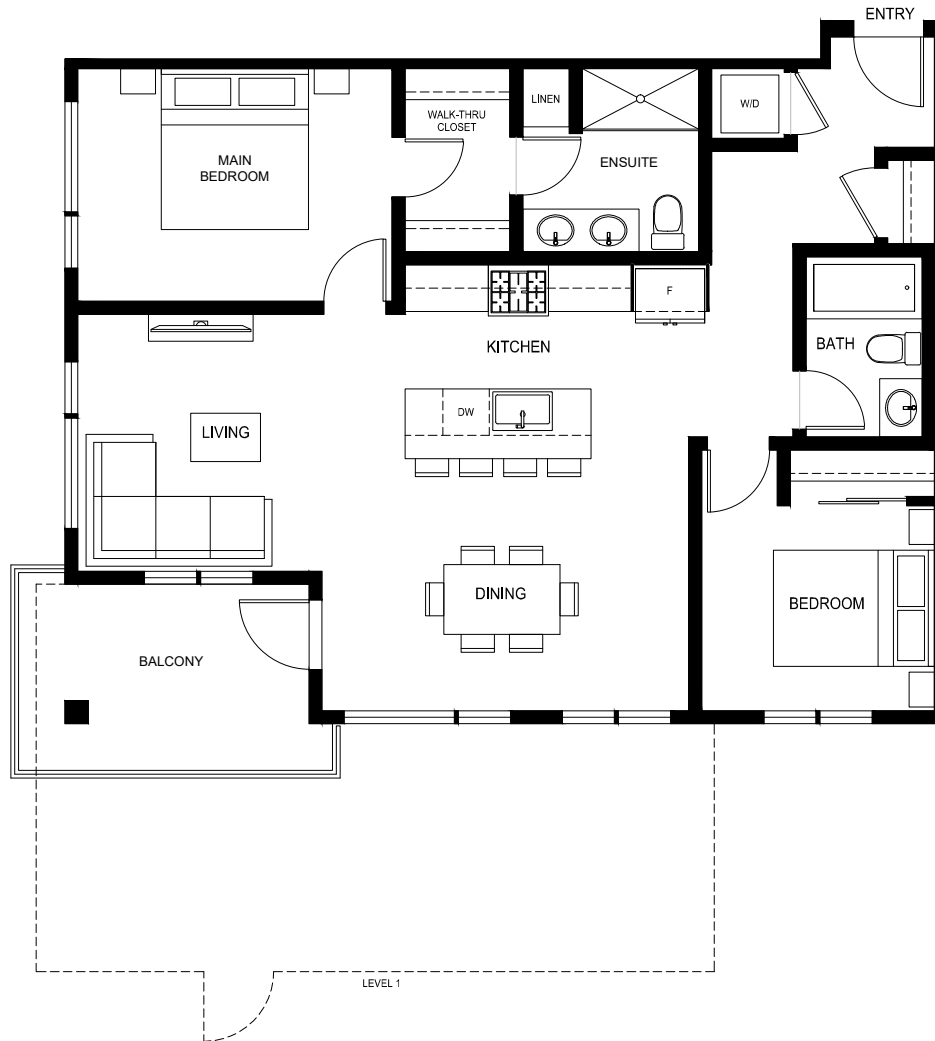

LEVEL 1

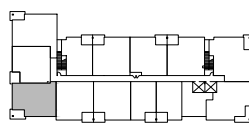

LEVEL 2

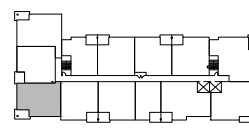

LEVEL 3-4





SOUTH VILLAGE CONDOS AT LATIMER HEIGHTS

PLAN D8 1,071 SQ.FT. 2 BED | 2 BATH

TWO BEDROOM

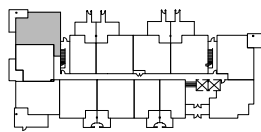
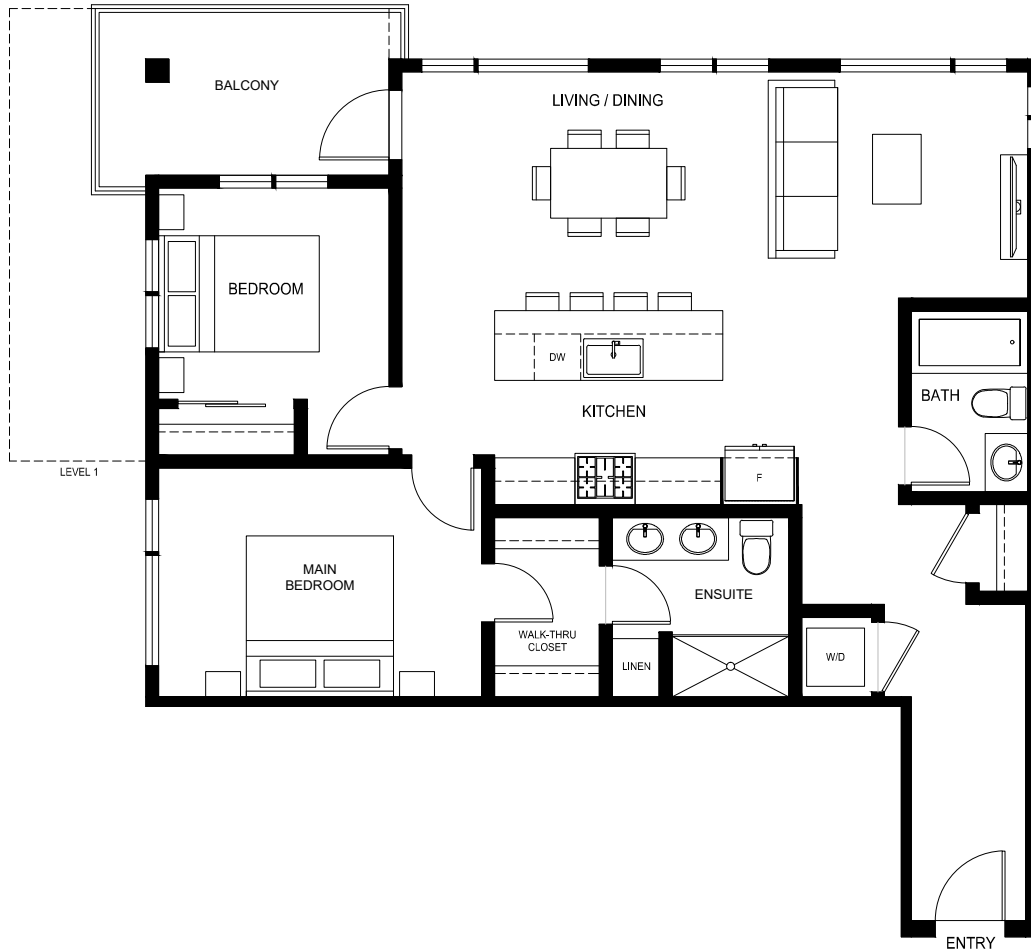

LEVEL 1

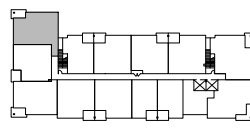

LEVEL 2

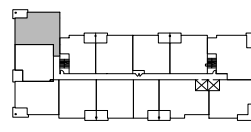

LEVEL 3-4





SOUTH VILLAGE CONDOS
AT LATIMER HEIGHTS

PLAN E
1,081 SQ.FT.
3 BED | 2 BATH

THREE BEDROOM

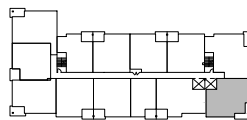
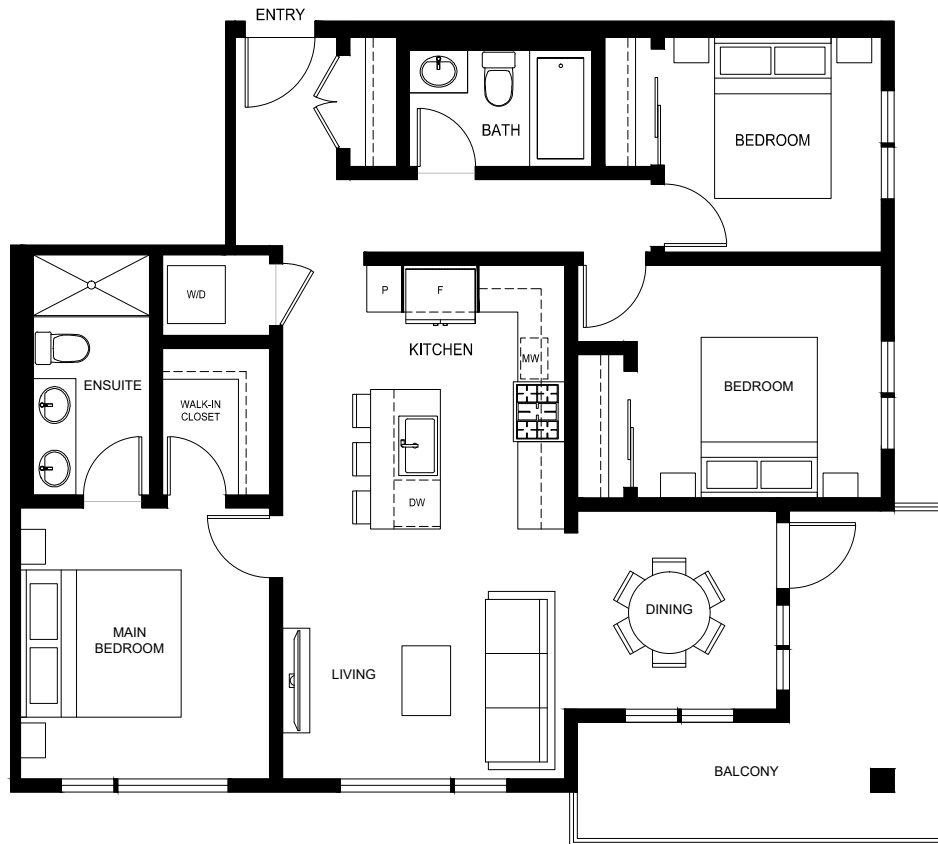

LEVEL 3-4





SOUTH VILLAGE CONDOS
AT LATIMER HEIGHTS

PLAN E-alt
1,040 SQ.FT.
3 BED | 2 BATH

THREE BEDROOM

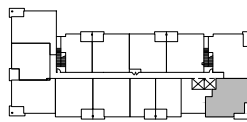
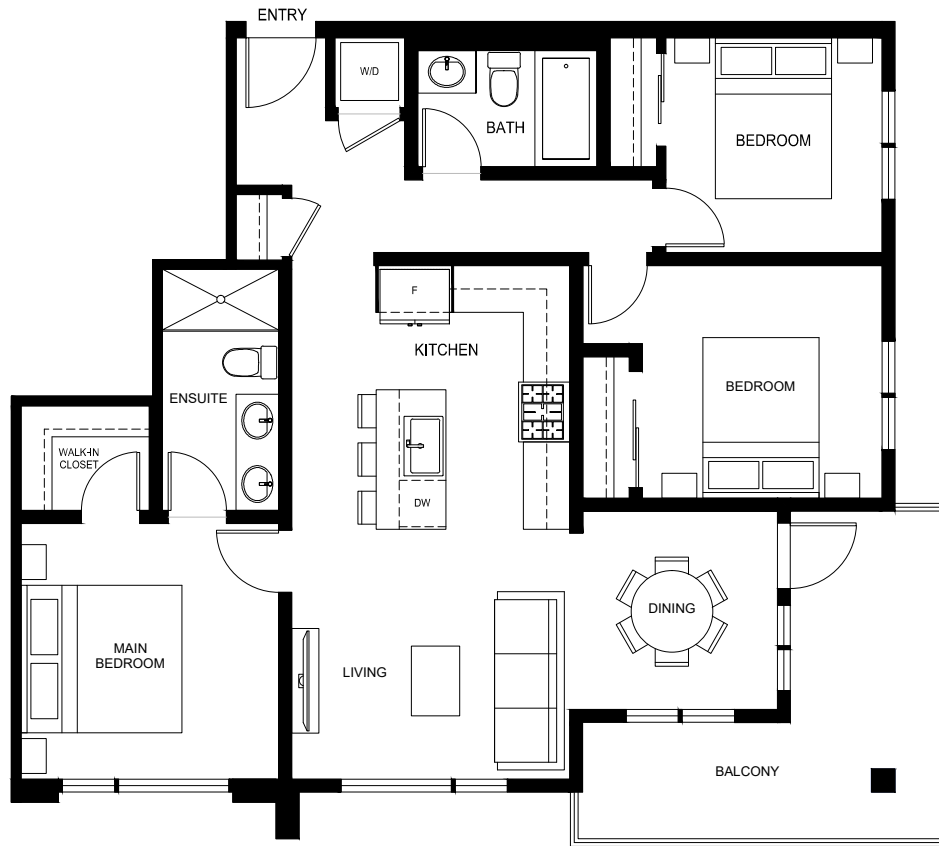

LEVEL 2





SOUTH VILLAGE CONDOS
AT LATIMER HEIGHTS

PLAN F
1,175 SQ.FT.
3 BED | 2 BATH

THREE BEDROOM

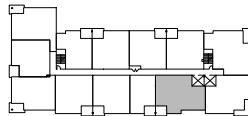

LEVEL 3-4





SOUTH VILLAGE CONDOS
AT LATIMER HEIGHTS

PLAN F1a

1,165 SQ.FT.

3 BED + FLEX | 2 BATH

THREE BEDROOM

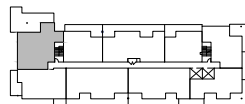
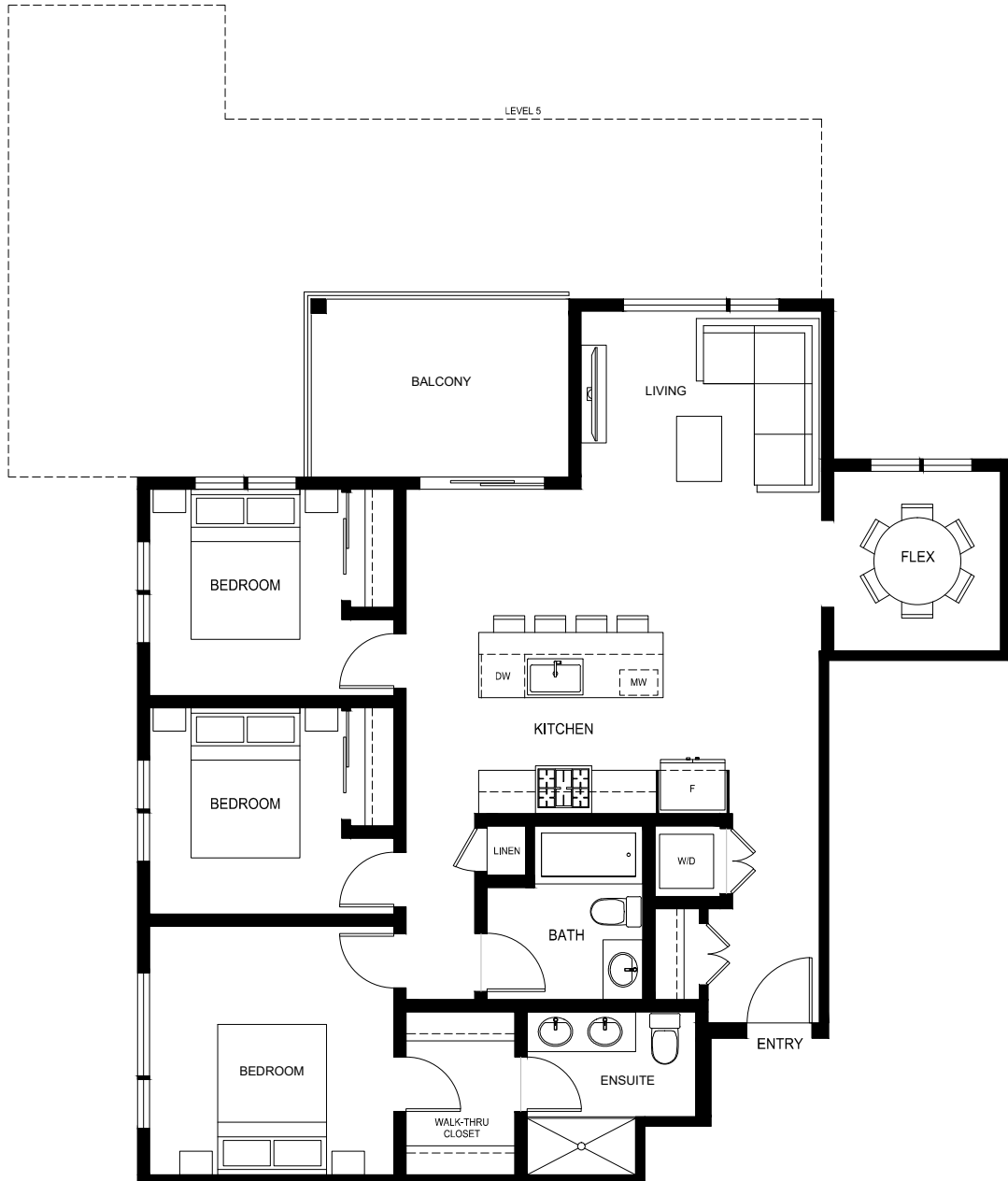

LEVEL 5

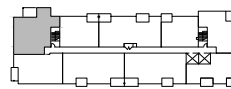

LEVEL 6





SOUTH VILLAGE CONDOS
AT LATIMER HEIGHTS

PLAN E4

1,204 SQ.FT.

3 BED + FLEX | 2 BATH

THREE BEDROOM

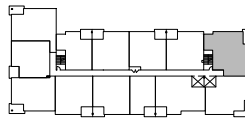
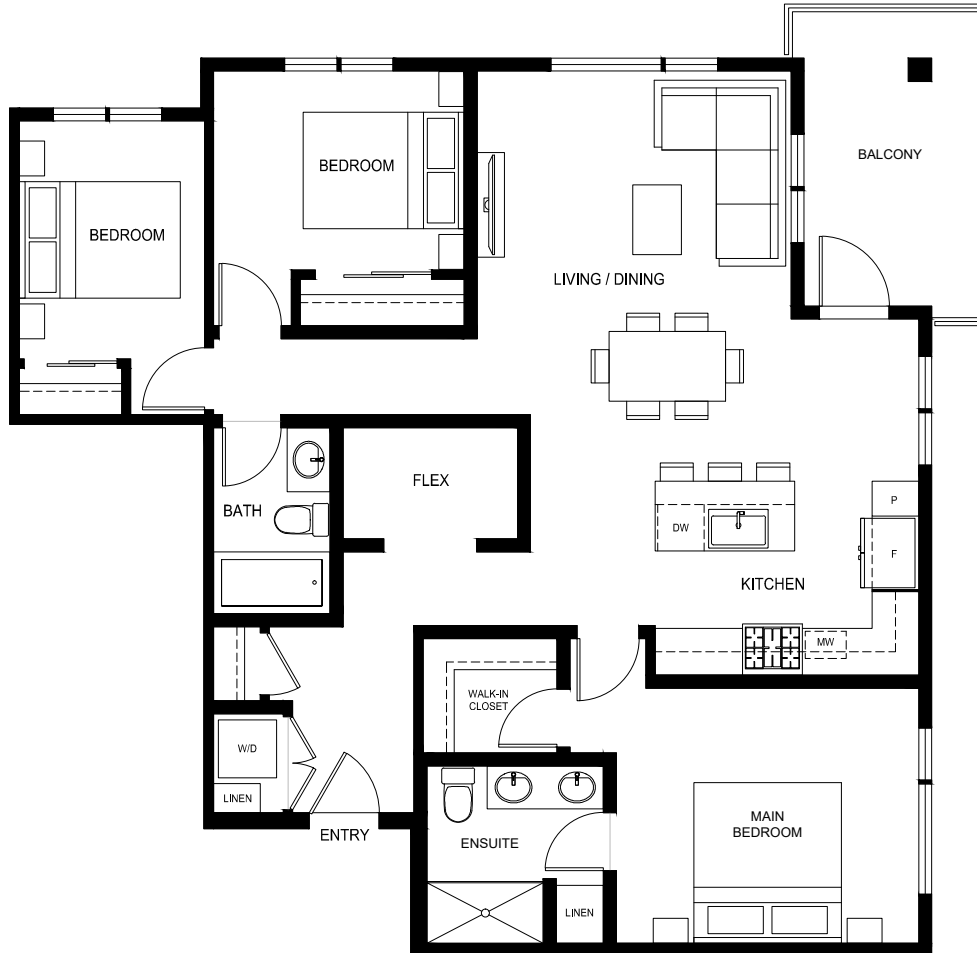

LEVEL 3-4





SOUTH VILLAGE CONDOS
AT LATIMER HEIGHTS

PLAN F2

1,262 SQ.FT.

3 BED + FLEX | 2 BATH

THREE BEDROOM

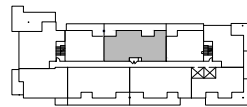
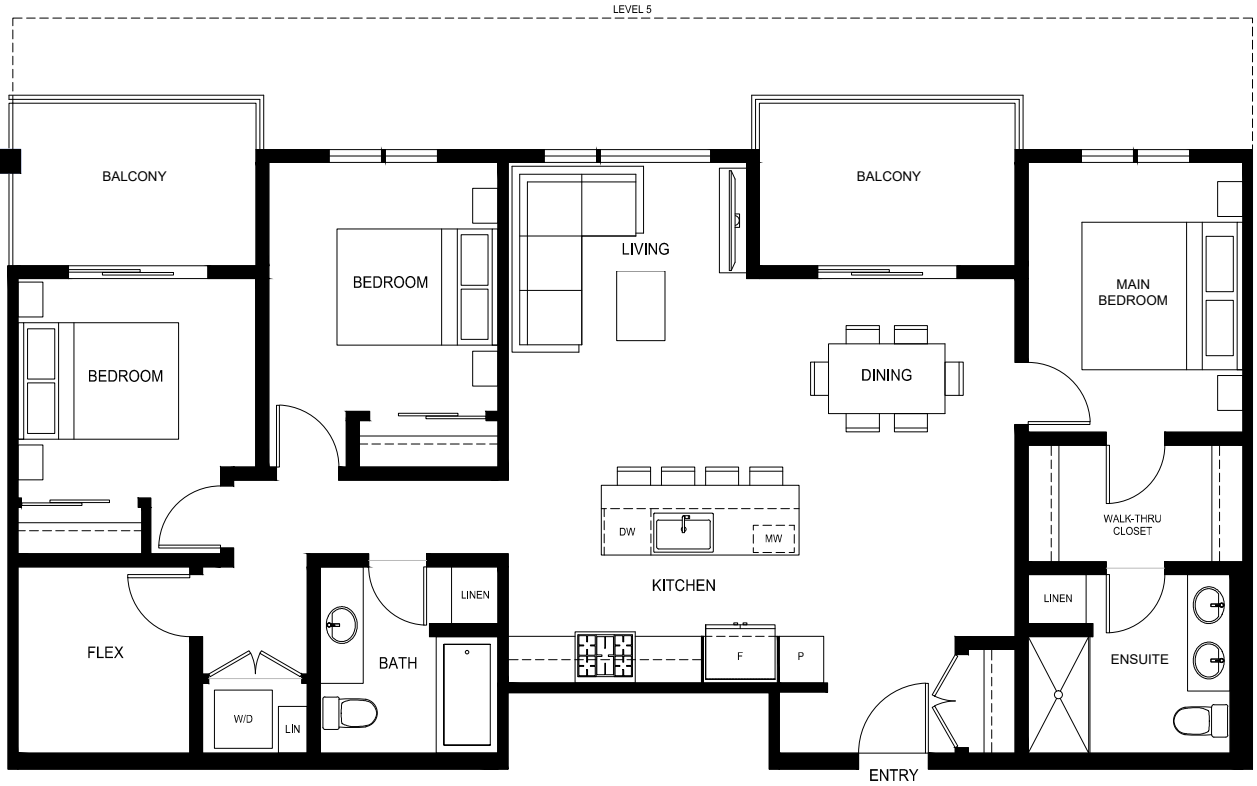

LEVEL 5

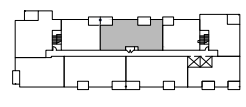

LEVEL 6





SOUTH VILLAGE CONDOS AT LATIMER HEIGHTS

PLAN F5

1,293 SQ.FT.

3 BED + Flex | 2 BATH

THREE BEDROOM

